



LMREA

Safe equipment. Smart mobility.

Designer and manufacturer

MOBIKIT

The MOBIKIT is a mobile computer cart designed to create a complete workstation right in the heart of your workshops, warehouses, or production areas. Sturdy and compact, it easily accommodates a monitor, PC, printer, and peripherals while remaining easy to move.

Its key feature: it is fully modular, with several possible configurations to suit your needs.

To simplify logistics, the MOBIKIT is available as an easy-to-transport kit or, optionally, pre-assembled and ready to use upon delivery.

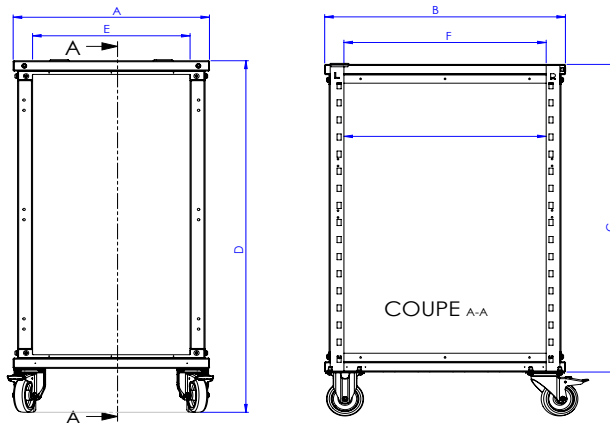

Structure Dimensions (mm)						
Part Number	Width 1 (A)	Width 2 (E)	Depth 1 (B)	Height 1 (C)	Height2 (D)	Enclosure
MOKRC-0B45.65.65[00-000]	450	325	650	650	780	No
MOKRC-0B45.65.90[00-000]	450	325	650	900	1030	No
MOKRC-0B53.65.65[00-000]	530	405	650	650	780	No
MOKRC-0B53.65.90[00-000]	530	405	650	900	1030	No
MOKRC-0B85.65.65[00-000]	850	725	650	650	780	No
MOKRC-0B85.65.90[00-000]	850	725	650	900	1030	No
MOKCR-0B45.65.65[00-000]	450	325	650	650	780	Yes
MOKCR-0B45.65.90[00-000]	450	325	650	900	1030	Yes
MOKCR-0B53.65.65[00-000]	530	405	650	650	780	Yes
MOKCR-0B53.65.90[00-000]	530	405	650	900	1030	Yes
MOKCR-0B85.65.65[00-000]	850	725	650	650	780	Yes
MOKCR-0B85.65.90[00-000]	850	725	650	900	1030	Yes

BENEFITS

Increased productivity: The workstation is positioned as close as possible to the operators. Less unnecessary movement.

Adaptable ergonomics: Height-adjustable tablet. Workstation tailored to each user.

Customizable configuration: Available in multiple sizes. Scalable solution to meet your needs.

Optimized shipping: Product shipped as a kit. Simpler and more cost-effective logistics.

Assembly options: Optional assembly service available. Ready to use upon delivery.





LMREA

Safe equipment. Smart mobility.

Designer and manufacturer

MOBIKIT OPTIONS

SHELF DIMENSIONS (mm)

Part Number	Type shelves	Finish	Shelf width	Shelf depth	Width 1 (A)
OMOK-TCB45.55-000[00-000]	Sliding	White	390	550	450
OMOK-TFB45.50-000[00-000]	Fixed	White	420	500	450
OMOK-TCB53.55-000[00-000]	Sliding	White	470	550	530
OMOK-TFB53.50-000[00-000]	Fixed	White	500	500	530
OMOK-TCB85.55-000[00-000]	Sliding	White	790	550	850
OMOK-TFB85.50-000[00-000]	Fixed	White	820	500	850

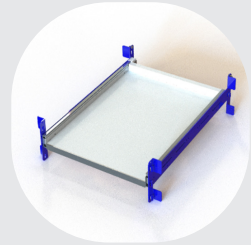

TYPE OF WHEELS

Part Number	Type of wheels
OMOK-R00-100-2PF2P (optional)	2 single-swivel casters, 2 swivel casters with brakes
OMOK-R00-100-2PF2F (included)	2 swivel casters with brakes, 2 fixed casters

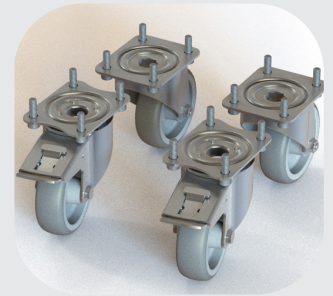

ARM TYPE

Part Number	Type of arm
OMOK-BR-G400.1	Left Arm (Straight)
OMOK-BR-G400.0	Left Arm (Extended)
OMOK-BR-D400.1	Right Arm (Straight)
OMOK-BR-D400.0	Right Arm (Extended)



HANDLE DIMENSIONS (mm)

Part Number	Width 1 (A)
OMOK-PGN45-000[00-000]	450
OMOK-PGN53-000[00-000]	530
OMOK-PGN85-000[00-000]	850

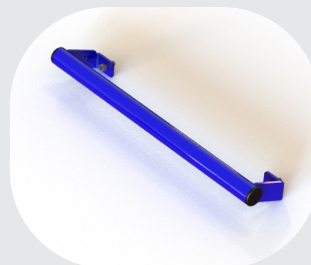

Visuels non contractuels | Veuillez nous consulter pour d'autres options

